

# Line Symmetry

## Focus on...

After this lesson, you will be able to...

- classify 2-D shapes or designs according to the number of lines of symmetry
- identify the line(s) of symmetry for a 2-D shape or design
- complete a shape or design given one half of the shape and a line of symmetry
- create a design that demonstrates line symmetry

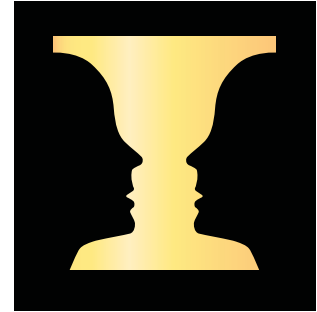
## Materials

- scissors
- isometric dot paper
- tracing paper
- grid paper

### line of symmetry

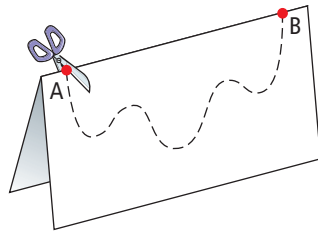
- a line that divides a figure into two reflected parts
- sometimes called a line of reflection or axis of symmetry
- a figure may have one or more lines of symmetry, or it may have none
- can be vertical, horizontal, or oblique (slanted)

This optical illusion was developed around 1915 by the Dutch psychologist Edgar Rubin. Like many optical illusions, this one involves a reflection. Look at the illusion. What do you see? Where is the line of reflection in this example?

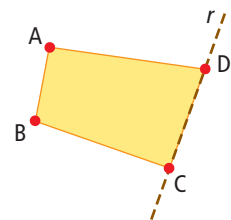


## Explore Lines of Symmetry

1. Fold a piece of paper in half. Mark two points, A and B, on the fold. Draw a wavy or jagged line between points A and B on one side of the paper. Cut along the line and then unfold your cut-out figure.
  - a) How does the fold affect the shape of the cutout?
  - b) Explain why it would make sense to refer to your fold line as a **line of symmetry**.



2. a) How could you fold a piece of paper so that a cutout shape would have two lines of symmetry? Use your method to create a cutout with two lines of symmetry.
  - b) Fold and cut a piece of paper to make a design with four lines of symmetry.
3. Draw an equilateral triangle on isometric dot paper. Then, cut it out using scissors. How many lines of symmetry are there? Explain how you arrived at your answer.
4. The diagram shows half of a shape. Line  $r$  represents a line of symmetry for the shape. Copy the diagram. Then, draw the complete shape.



## Reflect and Check

5. What are some ways to complete the shape in #4? Describe one way to a partner. See if your partner can follow your instructions.
6. Describe two different ways to find a line of symmetry for a symmetric 2-D shape. Which one do you prefer? Why?

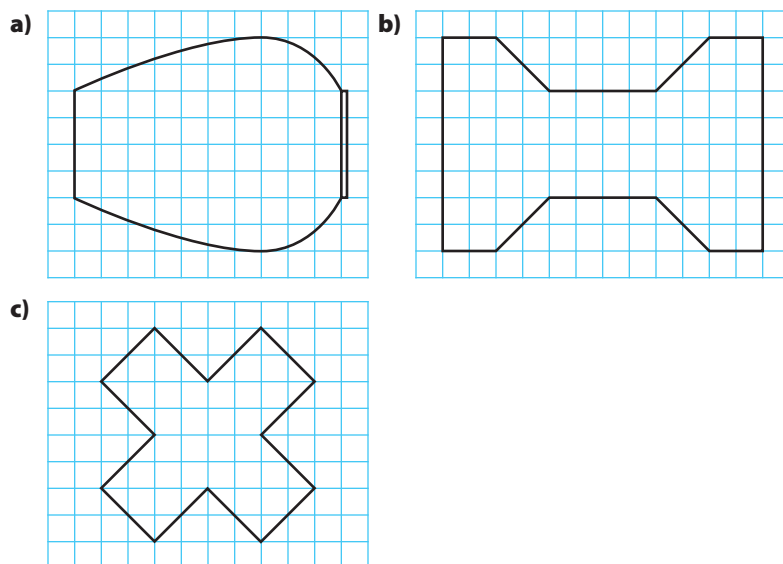
## Link the Ideas

Symmetry creates a sense of balance and, often, a sense of peace, tranquility, and perfection. A famous example of its use in architecture is the Taj Mahal, in Agra, India. Many parts of the building and grounds were designed and built to be perfectly symmetrical. Symmetry can also be seen in the pools that reflect an image of the structure. However, as with most cases of naturally occurring symmetry, the reflection in the pools is not perfect.



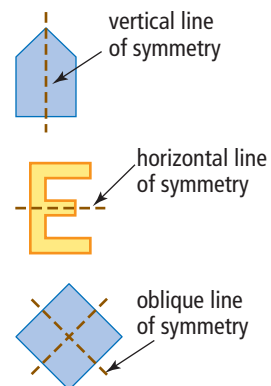
### Example 1: Find Lines of Symmetry

Each of the following demonstrates **line symmetry**. For each part, use a different method to find the line(s) of symmetry. State the number of lines of symmetry and describe each one.



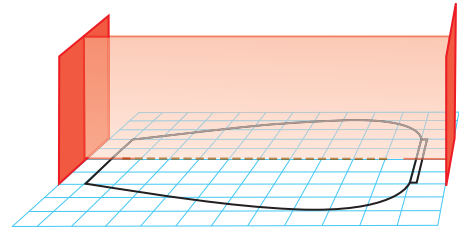
#### line symmetry

- a type of symmetry where an image or object can be divided into two identical, reflected halves by a line of symmetry
- identical halves can be reflected in a vertical, horizontal, or oblique (slanted) line of symmetry

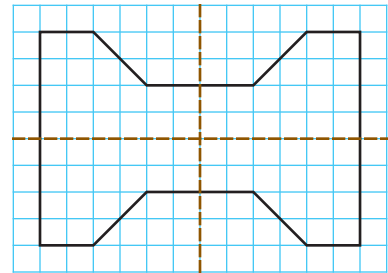


### Solution

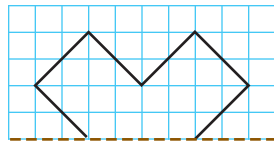
- a) By using a Mira™, you can see that there is one horizontal line of symmetry.



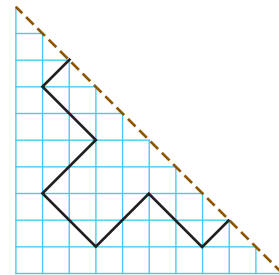
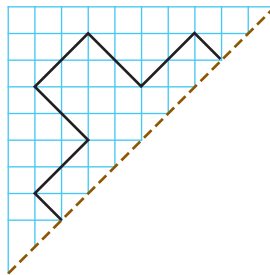
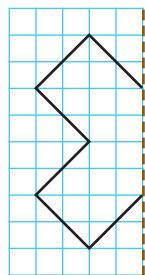
- b) You can find the lines of symmetry by counting on the grid. For this figure, there are the same number of squares above and below the horizontal line of symmetry. There are the same the number of squares to the left and right of the vertical line of symmetry. You can see that there are two lines of symmetry: one horizontal and one vertical.



- c) You can find the lines of symmetry by folding. If the shape on each side of the fold is the same, the fold line is a line of symmetry. This figure can be folded along four different lines to create mirrored shapes: one horizontal, one vertical, and two oblique.

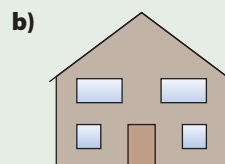
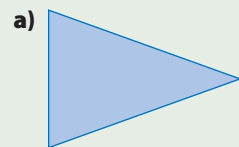


You can sketch the complete figures to prove that the fold lines in these images are, in fact, lines of symmetry?



### Show You Know

How many lines of symmetry are possible for each figure? Describe each line of symmetry as vertical, horizontal, or oblique.



## Example 2: Complete Drawings Using Symmetry

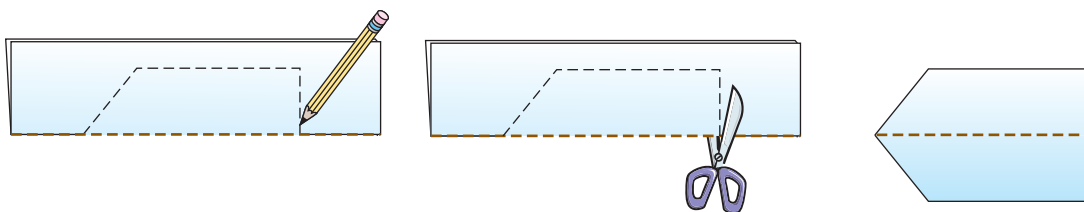
Each drawing shows half of a figure. The dashed brown line represents a line of symmetry for the figure. Draw a complete version of each figure.



### Solution

#### a) Method 1: Use Paper Folding

Fold a piece of paper in half. Draw the figure on the paper so that the line of symmetry is along the folded edge. Cut out the figure you have drawn. Unfold the paper to reveal the complete figure.

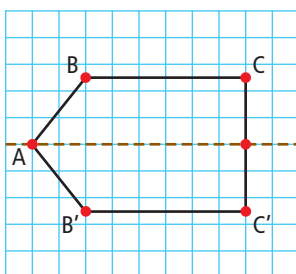
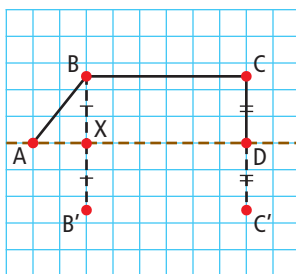
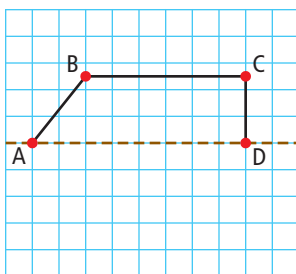


#### Method 2: Use Measurement or Counting

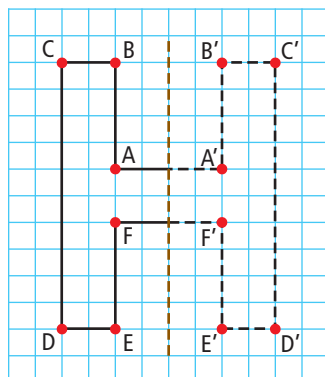
Draw the half figure onto a grid, and label the vertices A, B, C, and D. All points not on the line of symmetry are reflected on the opposite side of the line. In this figure, this is points B and C. The reflected points are drawn the same perpendicular distance from the fold line so that  $BX = B'X$  and  $CD = C'D$ . Join A to B', B' to C', and C' to D to complete the figure.

#### Literacy Link

$B'$  and  $C'$  are symbols used to designate the new positions of B and C after a transformation.  $B'$  is read as "B prime."

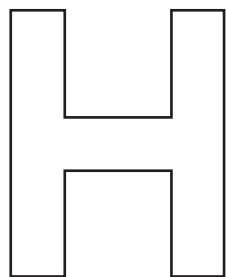


- b) One method is to mark the perpendicular distance from each vertex on the opposite side of the line of symmetry. Then, connect the lines to complete the figure.



What is another method that you could use to create this figure?

The completed figure is a block-letter H.  
Notice that the line of symmetry is not part of the final figure.

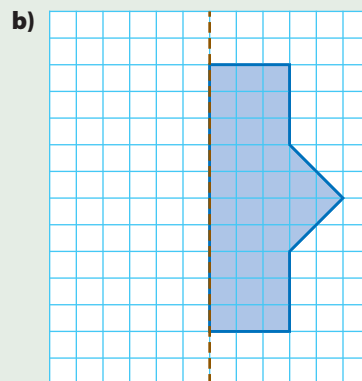
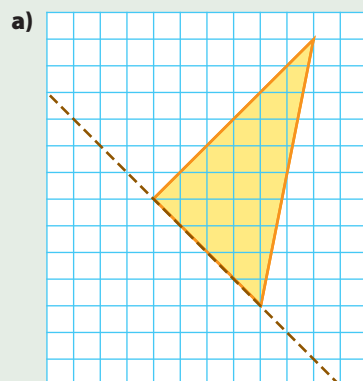


**WWW Web Link**

To explore more about symmetry, go to [www.mathlinks9.ca](http://www.mathlinks9.ca) and follow the links.

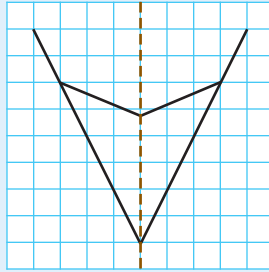
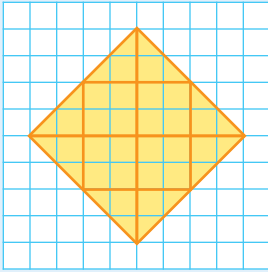
**Show You Know**

Copy each shape. Use the line of symmetry and a method of your choice to complete each shape.


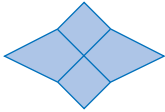
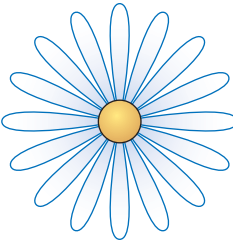


## Key Ideas

- Line symmetry exists whenever a shape or design can be separated into two identical halves by a line of symmetry. The line of symmetry, also known as a line of reflection, may or may not be part of the diagram itself.



- A shape or design can have any whole number of lines of symmetry.

<b>Shape</b>			
<b>Number of Lines of Symmetry</b>	0	2	16

Describe the lines of symmetry in these images.

- You can complete a symmetric drawing by folding or reflecting one half in the line of symmetry. The opposite halves are mirror images.

**O T | T O**

This name has one line of symmetry. If you know the first two letters you can complete the name by reflecting in the dashed line.

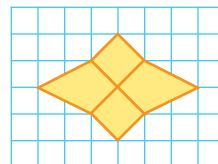
### Literacy Link

If a shape or design has symmetry, then it can be described as *symmetric* or *symmetrical*.

## Check Your Understanding

### Communicate the Ideas

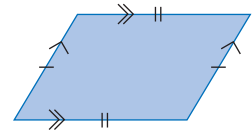
- Any rectangle has only two lines of symmetry. Do you agree or disagree with this statement? Explain. Use drawings to support your argument.
- Explain the changes you would need to make in the diagram so that the diagonal lines in the centre would become lines of symmetry. Redraw the diagram to match your answer.



3. Three students disagree on whether a parallelogram is symmetric. Sasha claims it is symmetric and has two lines of symmetry. Basil says it is symmetric and has four lines of symmetry. Kendra argues it is not symmetric since it has no lines of symmetry. Which of the three answers is correct? Explain why.

**Literacy Link**

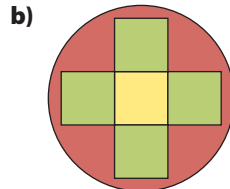
A parallelogram is a four-sided figure with opposite sides parallel and equal in length.



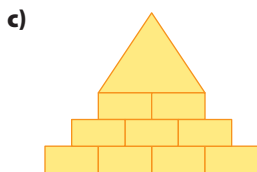
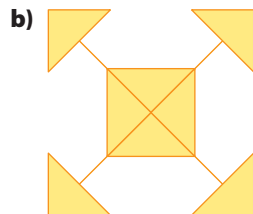
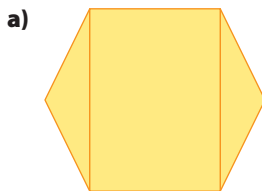
**Practise**

For help with #4 to #6, refer to Example 1 on pages 7–8.

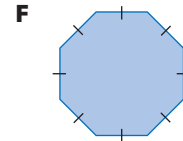
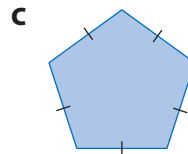
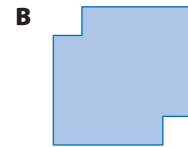
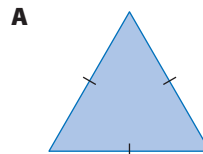
4. Where are the lines of symmetry for each figure? Draw a rough sketch of the figures in your notebook. Show all lines of symmetry in a different colour.



5. Redraw each diagram, showing all lines of symmetry.

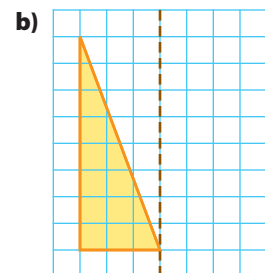
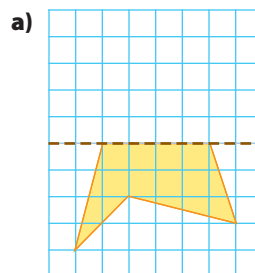


6. Which figures have only two lines of symmetry? Explain how you know.



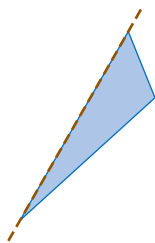
For help with #7 and #8, refer to Example 2 on pages 9–10.

7. If the dashed line is the line of symmetry, what does the complete diagram look like? Sketch your diagrams on grid paper.



8. Copy each figure. Use the line of symmetry shown to complete each figure.

a)

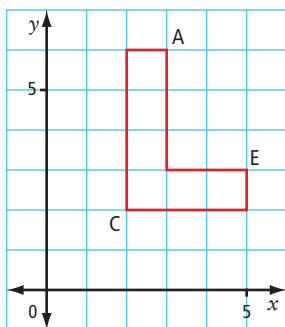


b)



### Apply

9. Copy the figure on a coordinate grid.



- Draw the reflection image if the  $y$ -axis is the line of reflection. Label the reflected vertices  $A'$ ,  $C'$ , and  $E'$ .
  - What are the coordinates of  $A'$ ,  $C'$ , and  $E'$  in your drawing in part a)?
  - Do the original figure and its reflection image show line symmetry? Explain.
10. Create a figure similar to question #9, using a coordinate grid.
- Translate the figure 4 units to the right.
  - What are the coordinates of  $A'$ ,  $C'$ , and  $E'$ ?
  - Do the original figure and its translation image show line symmetry? Explain your thinking.
  - Now, translate the figure you created in part a) 5 units down. Do the original figure and this new translation image show line symmetry? Explain.

11. Some regular shapes, such as an equilateral triangle, a square, or a regular hexagon, appear to show line symmetry when they are translated in one direction. Do you agree or disagree with this statement? Give examples to support your argument. Discuss your answer with a partner.

12. The Norwegian flag has a width to length ratio of 8 to 11.



- Does the flag have line symmetry? Explain your answer.
- What changes would be necessary in order to have exactly two lines of symmetry?

13. How many lines of symmetry does the flag of each of the following countries have?

a) Belgium



b) Canada



c) Scotland



d) Switzerland



### Did You Know?

There are only two sovereign states that have a square flag: Switzerland and Vatican City. The flag of Belgium is close to square, with a width to length ratio of 13:15.



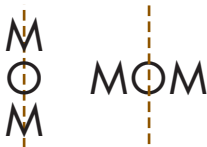
**14.** The number of lines of symmetry for a square flag can vary. Create sketches of flag designs that show 0, 1, 2, and 4 lines of symmetry.

**15.** Consider the upper-case block letters of the English alphabet.

A B C D E F G H I J K L M N  
O P Q R S T U V W X Y Z

- Which letters have a horizontal line of symmetry?
- Which letters have a vertical line of symmetry?
- Which letter(s) have both horizontal and vertical lines of symmetry?

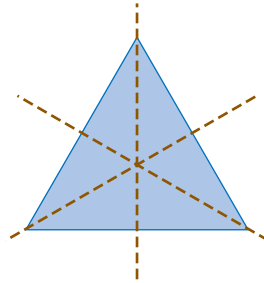
**16.** Using block letters, the word MOM can be written either vertically or horizontally. In each position, it has one vertical line of symmetry.



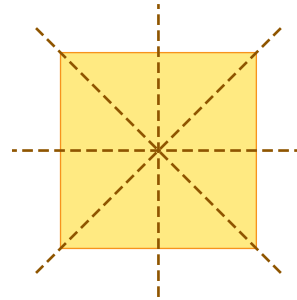
- Write at least two other words that have one vertical line of symmetry when printed vertically or horizontally.
  - Find a word that has a horizontal line of symmetry when it is printed horizontally, and a vertical line of symmetry when printed vertically.
  - Find a word that has one line of symmetry when it is printed vertically, but that is not symmetric when printed horizontally.
- 17. a)** Some single digits have line symmetry, depending on how they are printed. Which digits can demonstrate line symmetry?
- b)** Write a four-digit number that has two lines of symmetry when written horizontally.
- c)** What is a five-digit number that has two lines of symmetry?

**18.** Margaux is exploring regular polygons and line symmetry. She discovers that

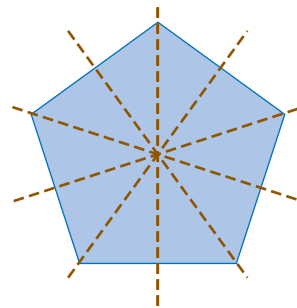
- an equilateral triangle has three interior angles and three lines of symmetry



- a square has four interior angles and four lines of symmetry



- a regular pentagon has five interior angles and five lines of symmetry



- Work with a partner to continue Margaux's exploration for a regular hexagon, heptagon, and octagon.
- What pattern do you discover?
- Does this pattern continue beyond an octagon? How do you know?

19. Consider these figures.

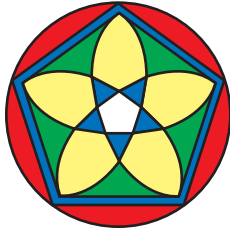


Figure A

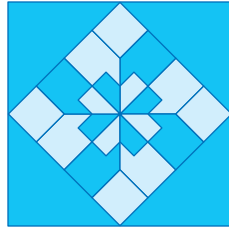


Figure B

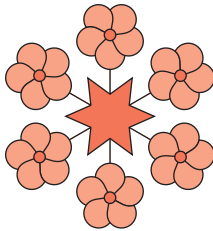


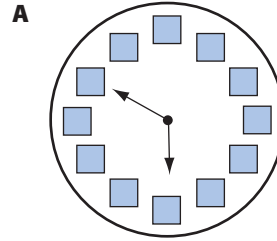
Figure C

- Which figure(s) shows line symmetry?
- What effect does the colour have on your answer in part a)?
- How many lines of symmetry does each figure you identified in part a) have?

### Extend

20. The triangle  $A(-6, 0)$   $B(-2, 0)$   $C(-2, -3)$  is first reflected in the  $y$ -axis. The resulting triangle is then reflected in a vertical line passing through  $(10, 0)$  to form  $\triangle A''B''C''$ . Describe one transformation that translates  $\triangle ABC$  directly to  $\triangle A''B''C''$ .

21. Consider the clocks shown.



- Explain whether each clock has line symmetry at some time? Ignore the different lengths of the hands on clock A.
- At what time(s) do your choices in part a) show true line symmetry?

22. Points  $A(4, 3)$  and  $B(6, -4)$  are reflected in the  $y$ -axis to form a quadrilateral. What is its area?

23. The triangle  $A(-6, 0)$   $B(-2, 0)$   $C(-2, -3)$  is reflected in the  $y$ -axis. The resulting image is then reflected in a diagonal line passing through the origin and  $(5, 5)$  to form  $\triangle A''B''C''$ . Describe one transformation that translates  $\triangle ABC$  directly to  $\triangle A''B''C''$ .

24. A three-dimensional object that is cut in half by a plane may be symmetric. Do you agree? Give examples.

### Literacy Link

A *plane* is a flat, two-dimensional surface that extends in all directions.

### Math Link

Imagine that you are working for a company that produces designs for many different uses, from playing cards to novelty items. Your job is to create appealing designs that can be used for a variety of products. As part of your portfolio, create a design that has at least two lines of symmetry. Draw your design on a half sheet of  $8.5 \times 11$  paper. Store it in the pocket in your Foldable. You will need this design for the Math Link: Wrap It Up! on page 39.

# Rotation Symmetry and Transformations

## Focus on...

After this lesson, you will be able to...

- tell if 2-D shapes and designs have rotation symmetry
- give the order of rotation and angle of rotation for various shapes
- create designs with rotation symmetry
- identify the transformations in shapes and designs involving line or rotation symmetry

## Materials

- scissors
- tracing paper

### centre of rotation

- the point about which the rotation of an object or design turns

### rotation symmetry

- occurs when a shape or design can be turned about its centre of rotation so that it fits onto its outline more than once in a complete turn



Some 2-D shapes and designs do not demonstrate line symmetry, but are still identified as having symmetry. The logo shown has this type of symmetry. What type of transformation can be demonstrated in this symbol?



## Explore Symmetry of a Rotation

Look carefully at the logo shown.

1. The logo has symmetry of rotation. What do you think that means?
2. Copy the logo using tracing paper. Place your drawing on top of the original figure. Put the point of your pencil on the tracing paper and rotate the design until the traced design fits perfectly over the original design.
  - a) Where did you have to put your pencil so that you were able to rotate your copy so that it fit over the original? How did you decide where to put your pencil? Explain why it is appropriate that this point is called the **centre of rotation**.
  - b) How many times will your tracing fit over the original design, in one complete turn?
  - c) Approximately how many degrees did you turn your tracing each time before it overlapped the original?
3. Work with a partner to try #2 with some other logos or designs.

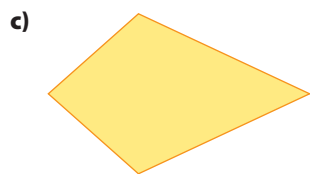
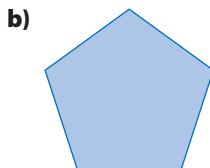
## Reflect and Check

4. What information can you use to describe **rotation symmetry**?

## Link the Ideas

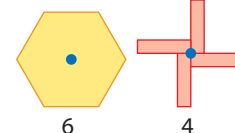
### Example 1: Find Order and Angle of Rotation

For each shape, what are the **order of rotation** and the **angle of rotation**? Express the angle of rotation in degrees and as a fraction of a revolution.



#### order of rotation

- the number of times a shape or design fits onto itself in one complete turn



#### angle of rotation

- the minimum measure of the angle needed to turn a shape or design onto itself
- may be measured in degrees or fractions of a turn
- is equal to  $360^\circ$  divided by the order of rotation

### Solution

Copy each shape or design onto a separate piece of tracing paper. Place your copy over the original, and rotate it to determine the order and angle of rotation.

	Order of Rotation	Angle of Rotation (Degrees)	Angle of Rotation (Fraction of Turn)
a)	2	$\frac{360^\circ}{2} = 180^\circ$	$\frac{1 \text{ turn}}{2} = \frac{1}{2} \text{ turn}$
b)	5	$\frac{360^\circ}{5} = 72^\circ$	$\frac{1 \text{ turn}}{5} = \frac{1}{5} \text{ turn}$
c)	1	$360^\circ$	1 turn

The figure in part c) does not have rotational symmetry.

### Show You Know

For each shape, give the order of rotation, and the angle of rotation in degrees and as a fraction. Which of the designs have rotation symmetry?



### Did You Know?

The Métis flag shown in part a) is a white infinity symbol on a blue background. The infinity symbol can represent that the Métis nation will go on forever. It can also be interpreted as two conjoined circles, representing the joining of two cultures: European and First Nations.

## Example 2: Relating Symmetry to Transformations

Examine the figures.

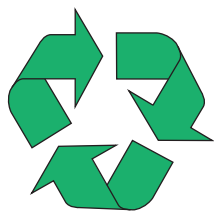


Figure 1

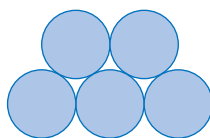


Figure 2



Figure 3

Visualize the translation and rotation of the figures. How does this help you determine the type of symmetry that they demonstrate?

- What type of symmetry does each figure demonstrate?
- For each example of line symmetry, indicate how many lines of symmetry there are. Describe whether the lines of symmetry are vertical, horizontal, or oblique.
- For each example of rotation symmetry, give the order of rotation, and the angle of rotation in degrees.
- How could each design be created from a single shape using translation, reflection, and/or rotation?

### Solution

The answers to parts a), b), and c) have been organized in a table.


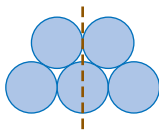
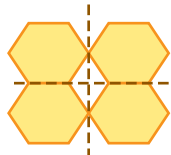
	Figure 1	Figure 2	Figure 3
<b>a)</b> Type of symmetry	rotation	line	rotation and line
<b>b)</b> Number and direction of lines of symmetry	No lines of symmetry 	Total = 1: vertical 	Total = 2: 1 vertical 1 horizontal 
<b>c)</b> Order of rotation	3	1	2
Angle of rotation	$\frac{360^\circ}{3} = 120^\circ$	$360^\circ$	$\frac{360^\circ}{2} = 180^\circ$

Figure 2 does not have rotational symmetry

- d) Figure 1 can be created from a single arrow by rotating it  $\frac{1}{3}$  of a turn about the centre of rotation, as shown.

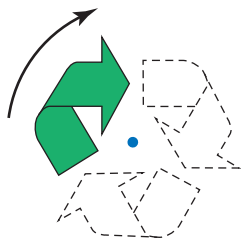
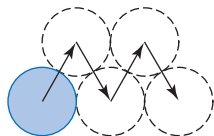
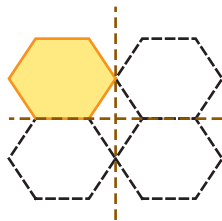


Figure 2 can be created from a single circle by translating it four times.



How could you use reflection to create this figure?

Figure 3 can be created from one of the hexagons by reflecting it in a vertical line, followed by a horizontal reflection (or vice versa).



How could you use translation and reflection to create this design?

### WWW Web Link

To see examples of rotation symmetry, go to [www.mathlinks9.ca](http://www.mathlinks9.ca) and follow the links.

### Show You Know

Consider each figure.

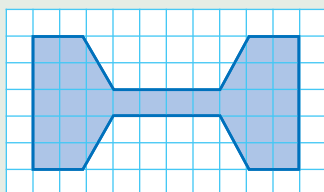


Figure A

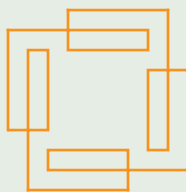
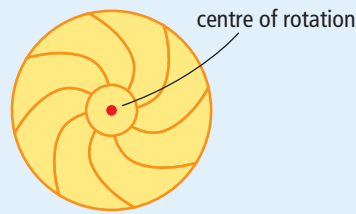
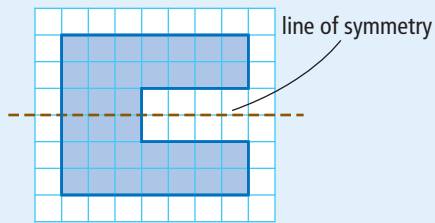


Figure B

- Does the figure show line symmetry, rotation symmetry, or both?
- If the figure has line symmetry, describe each line of symmetry as vertical, horizontal, or oblique.
- For each example of rotation symmetry, give the order of rotation.
- How could each design be created from a single part of itself using translations, reflections, or rotations?

## Key Ideas

- The two basic kinds of symmetry for 2-D shapes or designs are
  - line symmetry
  - rotation symmetry



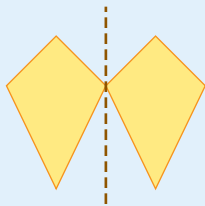
- The order of rotation is the number of times a figure fits on itself in one complete turn.

For the fan shown above, the order of rotation is 8.

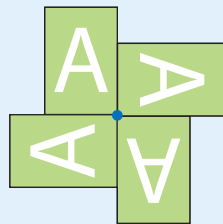
- The angle of rotation is the smallest angle through which the shape or design must be rotated to lie on itself. It is found by dividing the number of degrees in a circle by the order of rotation.

For the fan shown above, the angle of rotation is  $360^\circ \div 8 = 45^\circ$  or  $1 \div 8 = \frac{1}{8}$ , or  $\frac{1}{8}$  turn.

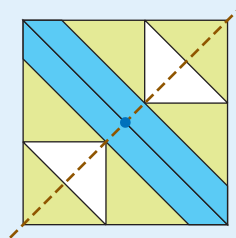
- A shape or design can have one or both types of symmetry.



line symmetry



rotation symmetry

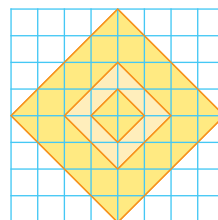


both

## Check Your Understanding

### Communicate the Ideas

- Describe rotation symmetry. Use terms such as centre of rotation, order of rotation, and angle of rotation. Sketch an example.
- Maurice claims the design shown has rotation symmetry. Claudette says that it shows line symmetry. Explain how you would settle this disagreement.

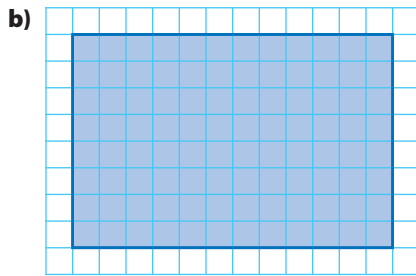
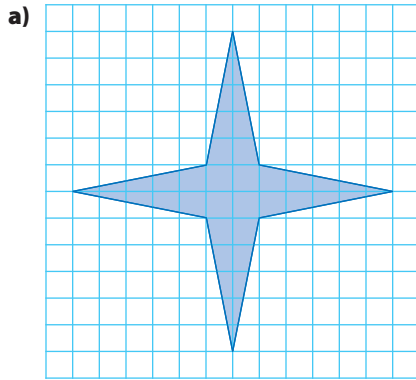


- Can a shape and its translation image demonstrate rotation symmetry? Explain with examples drawn on a coordinate grid.

## Practise

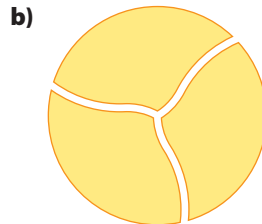
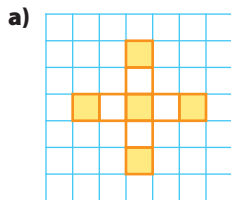
For help with #4 and #5, refer to Example 1 on page 17.

4. Each shape or design has rotation symmetry. What is the order and the angle of rotation? Express the angle in degrees and as a fraction of a turn. Where is the centre of rotation?



c) **1961**

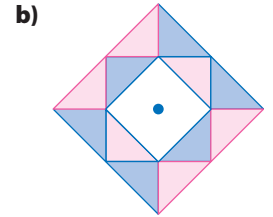
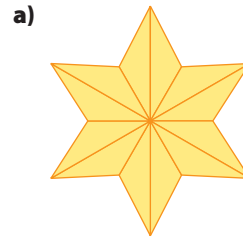
5. Does each figure have rotation symmetry? Confirm your answer using tracing paper. What is the angle of rotation in degrees?



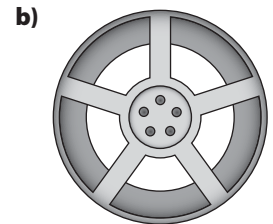
c) **XOX**

For help with #6 and #7, refer to Example 2 on pages 18–19.

6. Each design has line and rotation symmetry. What are the number of lines of symmetry and the order of rotation for each?

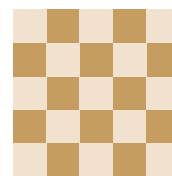


7. Each design has both line and rotation symmetry. Give the number of lines of symmetry and the size of the angle of rotation for each.



## Apply

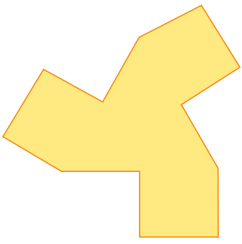
8. Examine the design.



- a) What basic shape could you use to make this design?  
 b) Describe how you could use translations, rotations, and/or reflections to create the first two rows of the design.



9. Consider the figure shown.

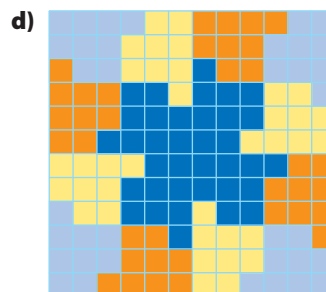
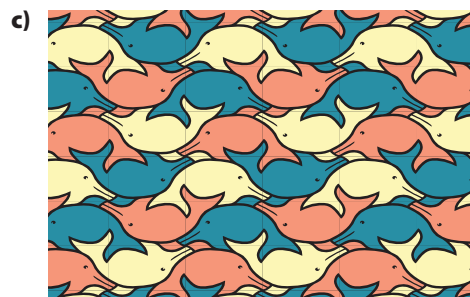
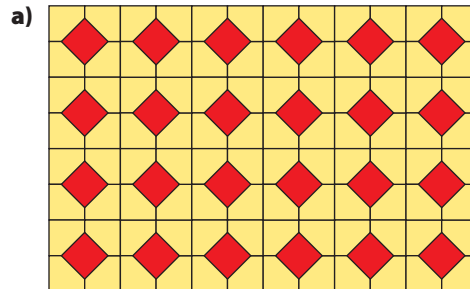


- What is its order of rotation?
  - Trace the figure onto a piece of paper. How could you create this design using a number of squares and triangles?
  - Is it possible to make this figure by transforming only one piece? Explain.
10. Many Aboriginal languages use symbols for sounds and words. A portion of a Cree syllabics chart is shown.

▽		△	◐	◑	◒	◓	◔	
e		i	ii	u	uu	a	aa	
◡			◑			◓	◔	
we			wii			wa	waa	
∨	◡	∧	∨	>	◓	<	◑	◑
pe		pi	pii	pu	puu	pa	paa	pwaa
∪	◡	∩	∪	⊃	◓	⊂	◑	◑
te	twe	ti	tii	tu	tuu	ta	taa	twaa
q	◡	ρ	◑	∂	∂	b	b	◑
ke	kwe	ki	kii	ku	kuu	ka	kaa	kwaa

- Select two symbols that have line symmetry and another two that have rotation symmetry. Redraw the symbols. Show the possible lines of symmetry and angles of rotation.
- Most cultures have signs and symbols with particular meaning. Select a culture. Find or draw pictures of at least two symbols from the culture that demonstrate line symmetry or rotation symmetry. Describe what each symbol represents and the symmetries involved.

11. Does each tessellation have line symmetry, rotation symmetry, both, or neither? Explain by describing the line of symmetry and/or the centre of rotation. If there is no symmetry, describe what changes would make the image symmetrical.

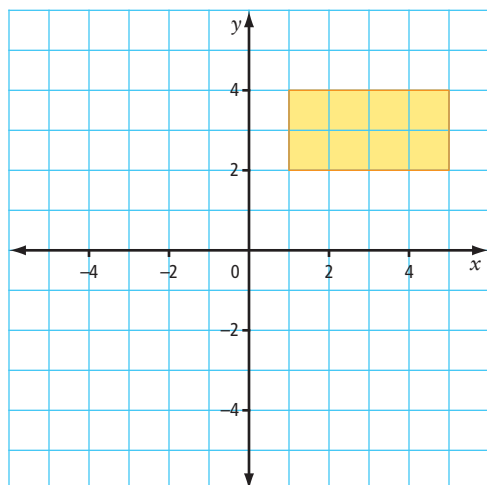


### Literacy Link

A *tessellation* is a pattern or arrangement that covers an area without overlapping or leaving gaps. It is also known as a tiling pattern.

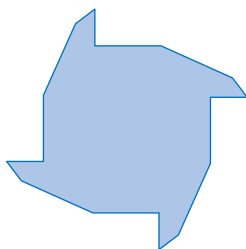
12. Reproduce the rectangle on a coordinate grid.

- a) Create a drawing that has rotation symmetry of order 4 about the origin. Label the vertices of your original rectangle. Show the coordinates of the image after each rotation.



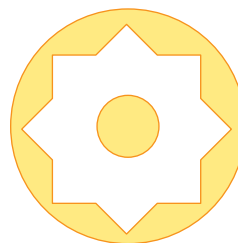
- b) Start again, this time using line symmetry to make a new design. Use the  $y$ -axis and then the  $x$ -axis as a line of symmetry. How is this new design different from the one that you created in part a)?

13. Sandra makes jewellery. She created a pendant based on the shape shown.



- a) Determine the order and the angle of rotation for this design.  
 b) If Sandra's goal was to create a design with more than one type of symmetry, was she successful? Explain.

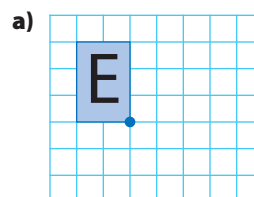
14. Alain drew a pendant design that has both line and rotation symmetry.



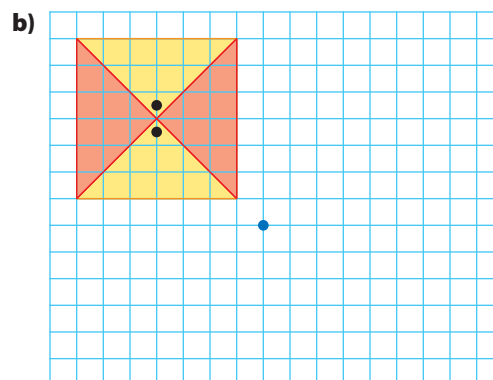
- a) How many lines of symmetry are in this design? What is the size of the smallest angle between these lines of symmetry?  
 b) What are the order and the angle of rotation for this design?

15. Imagine you are a jewellery designer. On grid paper, create a design for a pendant that has more than one type of symmetry. Compare your design with those of your classmates.

16. Copy and complete each design. Use the centre of rotation marked and the order of rotation symmetry given for each part.



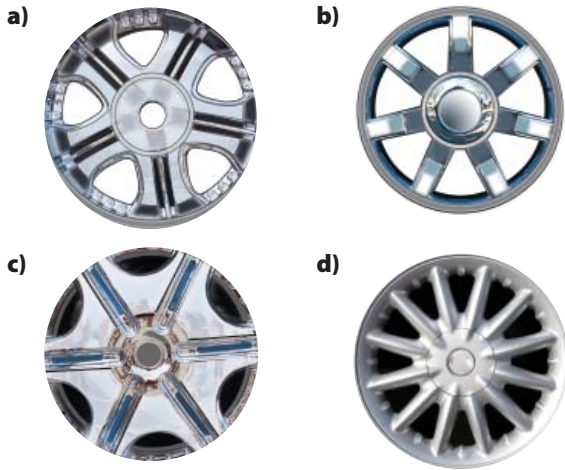
Order of rotation: 2



Order of rotation: 4

Hint: Pay attention to the two dots in the centre of the original shape.

17. Automobile hubcaps have rotation symmetry. For each hubcap shown, find the order and the angle of rotation in degrees.



18. a) Sometimes the order of rotation can vary depending on which part of a diagram you are looking at. Explain this statement using the diagram below.

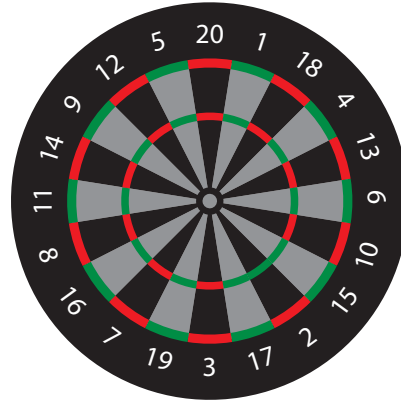


b) How would you modify this diagram so that it has rotation symmetry?

19. a) Describe the symmetry shown on this playing card.  
 b) Why do you think the card is designed like this?  
 c) Does this playing card have line symmetry? Explain.



20. Two students are looking at a dart board. Rachelle claims that if you ignore the numbers, the board has rotation symmetry of order 10. Mike says it is order 20. Who is correct? Explain.



21. a) Which upper-case letters can be written to have rotation symmetry?  
 b) Which single digits can be considered to have rotation symmetry? Explain your answer.  
 c) Create a five-character Personal Identification Number (PIN) using letters and digits that have rotational symmetry. In addition, your PIN must show line symmetry when written both horizontally and vertically.
22. Some part of each of the objects shown has rotation symmetry of order 6. Find or draw other objects that have rotation symmetry of order 6. Compare your answers with those of some of your classmates.



**23.** Organizations achieve brand recognition using logos. Logos often use symmetry.

- a) For each logo shown, identify aspects of symmetry. Identify the type of symmetry and describe its characteristics.



A

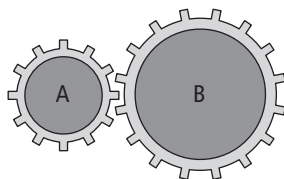


B

- b) Find other logos that have line symmetry, rotation symmetry, or both. Use pictures or drawings to clearly show the symmetry involved.

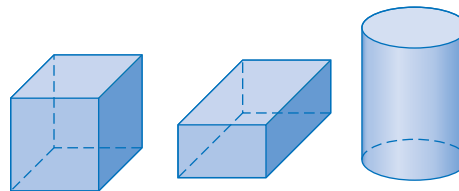
### Extend

**24.** Two gears are attached as shown.

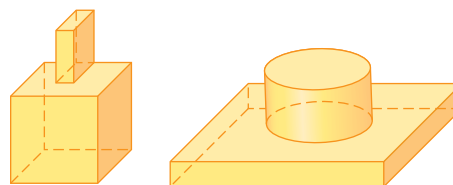


- a) The smaller gear has rotation symmetry of order  $m$ . What is the value of  $m$ ? What could  $m$  represent?
- b) The larger gear has rotation symmetry of order  $n$ . Find the value of  $n$ .
- c) When the smaller gear makes six full turns, how many turns does the larger gear make?
- d) If gear A has 12 teeth, and gear B has 16 teeth, how many turns does B make when A makes 8 turns?
- e) If gear A has  $x$  teeth, and gear B has  $y$  teeth, how many turns does B make when A makes  $m$  turns?

**25.** Examine models or consider these drawings of the 3-D solids shown.



Group A



Group B

- a) Select one object from each group. Discuss with a partner any symmetry that your selected objects have.
- b) For one of the objects you selected, describe some of its symmetries. Use appropriate mathematical terminology from earlier studies of solids and symmetry.
- 26.** A circle has a radius of length  $r$ . If a chord with length  $r$  is rotated about the centre of the circle by touching end to end, what is the order of rotation of the resulting shape? Explain.

### Math Link

Your design company continues to expand. As a designer, you are constantly trying to keep your ideas fresh. You also want to provide a level of sophistication not offered by your competitors. Create another appealing design based on the concepts of symmetry you learned in section 1.2. Sketch your design on a half sheet of  $8.5 \times 11$  paper. Store it in the pocket in your Foldable. You will need this design as part of Math Link: Wrap It Up! on page 39.

# Surface Area

## Focus on...

After this lesson, you will be able to...

- determine the area of overlap in composite 3-D objects
- find the surface area for composite 3-D objects
- solve problems involving surface area

### surface area

- the sum of the areas of all the faces of an object

### Materials

- small disks or pennies
- small boxes or dominoes

### Literacy Link

An object that is made from two or more separate objects is called a *composite object*.



Red blood cells are the shape of very tiny disks. They have a thickness of 2.2 microns and a diameter of 7.1 microns. A micron is another term for a micrometre—one millionth of a metre. Red blood cells absorb oxygen from the lungs and carry it to other parts of the body. The cell absorbs oxygen through its surface.

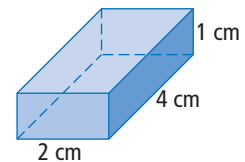
The disease multiple myeloma causes the red blood cells to stick together. How would this affect the **surface area** of the cells?

## Explore Symmetry and Surface Area

- Use a small disk to represent a single red blood cell. Estimate the surface area of the disk.
  - Stack four disks. Estimate the surface area of the stack of disks.
  - How did you estimate the surface area for parts a) and b)? Compare your method of estimation with your classmates' methods.
  - How does the total surface area of the four separate disks compare to the surface area of the four stacked disks? By what percent did the total surface area decrease when the disks were stacked?



- Some medicine is shipped in small boxes that measure 1 cm by 4 cm by 2 cm. Six boxes are wrapped and shipped together. Working with a partner, use models to help answer the following questions.



- If the arrangement of the six boxes must form a rectangular prism, how many arrangements are possible?

b) The cost to ship a package depends partly on total surface area. Would it be cheaper to ship the boxes in part a) individually, or wrapped together in plastic? If you wrapped the boxes together, which arrangement do you think will cost the least to ship? Explain.

3. You want to waterproof a tent. You need to determine the surface area of the tent's sides and ends to purchase the right amount of waterproofing spray. You do not have to waterproof the bottom. Calculate the surface area. Give your answer to the nearest tenth of a square metre.



How can you use the Pythagorean relationship to find the dimension for the tent's sides?

### Reflect and Check

- How can symmetry help you find the surface area in each of the three situations? Explain.
- How does the surface area of a composite object compare with the sum of the surface areas of its separate parts? Explain.

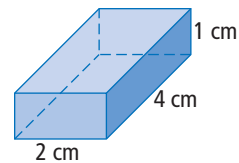
### Link the Ideas

Different formulas can be used to find the surface area of a rectangular prism or a cylinder. There is one formula that works for both:

Surface Area = 2(area of base) + (perimeter of base) × (height)

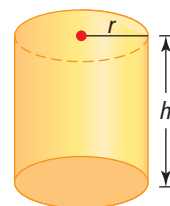
$$\begin{aligned} SA_{\text{prism}} &= 2(\text{area of base}) + (\text{perimeter of base}) \times (\text{height}) \\ &= 2(4 \times 2) + (4 + 2 + 4 + 2) \times 1 \\ &= 16 + 12 \\ &= 28 \end{aligned}$$

The surface of this prism is 28 cm<sup>2</sup>.



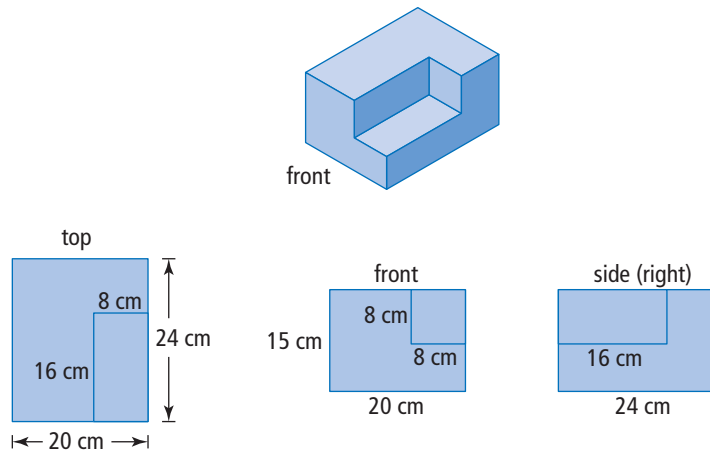
Using this same approach, the formula for the surface area of a cylinder is

$$\begin{aligned} SA_{\text{cylinder}} &= 2(\text{area of base}) + (\text{perimeter of base}) \times (\text{height}) \\ &= 2(\pi r^2) + (2\pi r)h \\ &= 2\pi r^2 + 2\pi rh \end{aligned}$$



### Example 1: Calculating Surface Area of a Solid

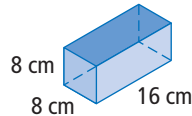
Consider the solid shown, in which all angles are right angles.



- What are the dimensions of the cutout piece?
- What is the total surface area of the solid?

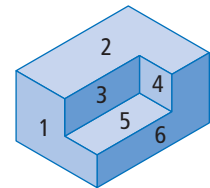
#### Solution

- The cutout notch is a right rectangular prism. The dimensions of the notch are 8 cm by 8 cm by 16 cm.



- Method 1: Find the Surface Area of Each Face**

You need to find the area of nine faces, including the faces of the notch. Number the faces to help keep track of the faces you have completed. Let the left face be #7, the back #8, and the bottom #9.



Why do you subtract  $8 \times 8$  in the calculation for face 1?

Face	Calculation	Surface Area (cm <sup>2</sup> )
1	$15 \times 20 - (8 \times 8)$	236
2	$20 \times 24 - (8 \times 16)$	352
3	$8 \times 16$	128
4	$8 \times 8$	64
5	$8 \times 16$	128
6	$15 \times 24 - (8 \times 16)$	232
7 (left side)	$15 \times 24$	360
8 (back)	$15 \times 20$	300
9 (bottom)	$20 \times 24$	480
	Total Surface Area:	2280

The total surface area of the solid is 2280 cm<sup>2</sup>.

### Method 2: Use Symmetry

Calculate the surface area of only certain faces.

$$\text{face 9 (bottom): } 20 \times 24 = 480$$

$$\text{face 8 (back): } 15 \times 20 = 300$$

$$\text{face 7 (left side): } 15 \times 24 = \underline{360}$$

$$\text{Total of 3 faces: } 1140$$

Notice that, by symmetry, opposite faces match.

$$\text{face 2 + face 5 = face 9}$$

$$\text{face 1 + face 4 = face 8}$$

$$\text{face 6 + face 3 = face 7}$$

You can obtain the surface area by doubling the area for

$$\text{face 9 + face 8 + face 7.}$$

$$1140 \times 2 = 2280$$

The surface area of the solid is  $2280 \text{ cm}^2$ .

Why could the following be used to calculate the surface area?

$$SA = 2(15 \times 20) + 2(15 \times 24) + 2(20 \times 24)$$

### Show You Know

A set of concrete steps has the dimensions shown. Estimate and then calculate the surface area of the faces that are not against the ground. What is the area of the surface that is against the ground? Explain your answer.



### Did You Know?

If you cut a right rectangular piece out of one corner of a rectangular prism (Figure 2), the surface area does not change from that of the original prism (Figure 1). The surface area does change if the cutout extends across the solid (Figure 3). Explain why.



Figure 1



Figure 2

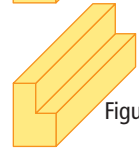
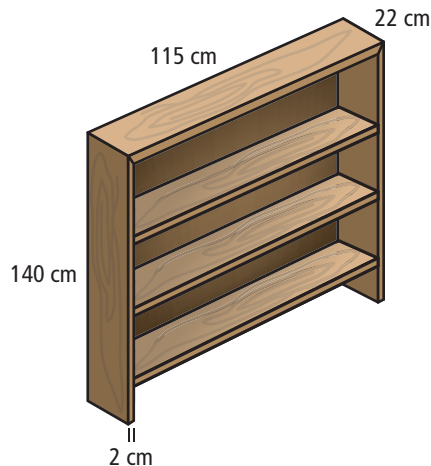


Figure 3

### Example 2: Painting a Bookcase

Raubyn has made a bookcase using wood that is 2 cm thick for the frame and shelves. The back is thin plywood. He wants to paint the entire visible surface. He will not paint the back, which stands against a wall.

- What assumptions could you make about how the bookcase is painted?
- What surface area does Raubyn need to paint?



### Strategies

Make an Assumption



### Solution

- a) Assumptions could include:

He paints the undersides of the three shelves.  
The shelves are set inside the ends of the bookcase.  
He paints the visible or inside back surface.  
He does not paint the area of the base on which the bookcase stands.  
Raubyn paints the bookcase after it is assembled.

Why would this assumption make a difference?

- b) Group similar surfaces together.

Group 1: underside of top, and top and bottom of each of the three shelves.

$$\begin{aligned}\text{Surface area} &= 7 \times 111 \times 22 \\ &= 17\,094\end{aligned}$$

Why is this measurement 111 cm, rather than 115 cm?

Group 2: outside of top and sides.

$$\begin{aligned}\text{Surface area} &= 22 \times 115 + 2(22 \times 140) \\ &= 8690\end{aligned}$$

Group 3: back of bookcase that shows inside and front edges of the three shelves.

$$\begin{aligned}\text{Surface area} &= 111 \times 138 \\ &= 15\,318\end{aligned}$$

This measurement is 138, rather than 140, because the top piece is 2 cm thick. Notice that no surface area was subtracted to account for the back edges of the shelves, and none was added to account for the front edges. Using symmetry, explain why this works.

Group 4: front edges of top and sides.

$$\begin{aligned}\text{Surface area} &= 2(2 \times 138) + 2 \times 115 \\ &= 782\end{aligned}$$

Total surface area:

$$17\,084 + 8690 + 15\,318 + 782 = 41\,884$$

The surface area Raubyn needs to paint is  $41\,884 \text{ cm}^2$ .

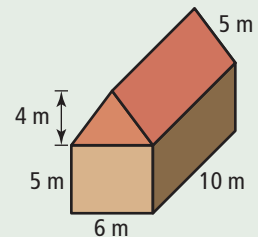
### WWW Web Link

For information on how to calculate the surface area of different shapes, go to [www.mathlinks9.ca](http://www.mathlinks9.ca) and follow the links.

### Show You Know

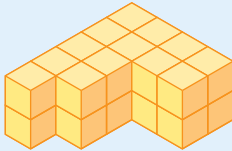
Consider the building shown.

- a) Estimate the outside surface area of the building.  
b) Calculate the outside surface area. Determine your answer two different ways.  
c) Which method do you prefer? Why?



## Key Ideas

- To determine the surface area of a composite 3-D object, decide which faces of the object you must consider and what their dimensions are.
- There are several ways to determine the surface area of an object.
  - Determine the area of each face. Add these areas together.
  - Use symmetry to group similar faces. Calculate the area of one of the symmetrical faces. Then, multiply by the number of like faces. This reduces the number of faces for which you need to calculate the surface area.



The top of this object has an area of 13 square units.  
The bottom must have the same area.

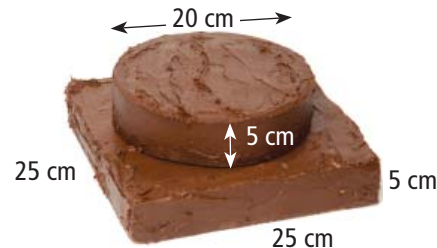
- Consider how the shape is made from its component parts. Determine the surface area of each part. Then, remove the area of overlapping surfaces.

## Check Your Understanding

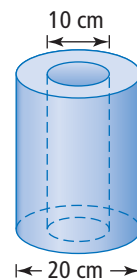
### Communicate the Ideas

1. Build two different solid objects each using 24 interlocking cubes.
  - a) Explain how symmetry could help you determine the surface area of one of your objects.
  - b) Slide the two objects together. What is the area of overlap between the objects?
  - c) How does the overlap affect the total surface area of your composite object?

2. Nick makes a two-layer cake. Instead of icing, he puts strawberry jam between the two layers. He plans to cover the outside of the cake with chocolate icing. Describe how he can calculate the area that needs icing.



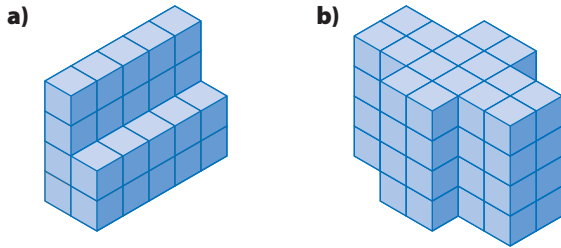
3. Explain how you would calculate the surface area of the object shown.



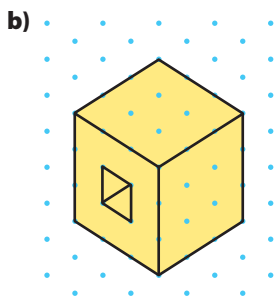
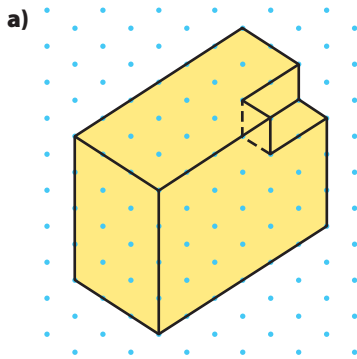
## Practise

For help with #4 to #7, refer to Example 1 on pages 28–29.

4. Each object has been constructed from centimetre cubes. Estimate and then calculate the surface area.

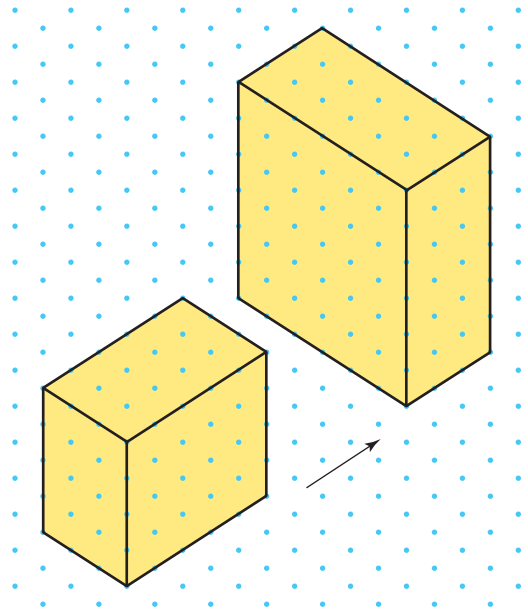


5. The following objects have been drawn on isometric dot paper where the distance between dots is 2 cm. Determine the surface area of each object.

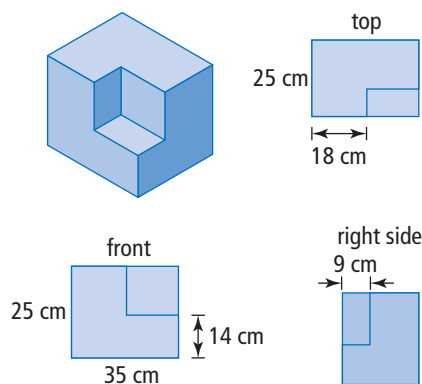


Note: The hole extends all the way through the block.

6. a) If you build the rectangular solids and slide them together as shown, what is the area of the overlap? Assume the dots are 1 cm apart.



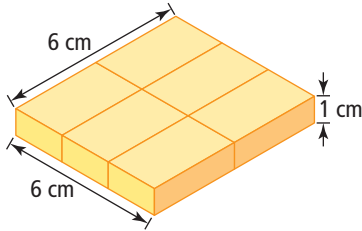
- b) What is the surface area when the solids are together?
7. Examine the solid and its views. All angles are right angles.



- a) What are the dimensions of the cutout piece?
- b) Explain how cutting out the corner piece will affect the surface area of the original rectangular solid.

For help with #8 and #9, refer to Example 2 on pages 29–30.

8. Six small boxes, all the same size, have been arranged as shown.

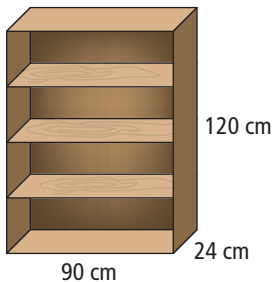


- What are the dimensions of a single box?
- What is the surface area for the arrangement of the six boxes?
- What is the ratio of the answer in part b) to the total surface area of the six separate boxes?

**WWW Web Link**

To see how surface area changes when a composite object is broken apart, go to [www.mathlinks9.ca](http://www.mathlinks9.ca) and follow the links.

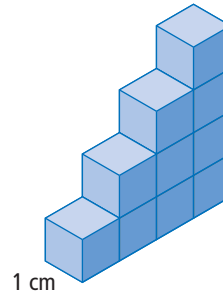
9. Examine the bookshelf. It is constructed of thin hardwood. The top, bottom, and all three shelves are the same size. There is an equal distance between the top, the shelves, and the base.



- What is the surface area of one shelf? Include both sides, but ignore the edges.
- What is the total surface area of the bookcase?
- What is the fewest number of surfaces for which you need to find the surface area in order to answer part b)?

**Apply**

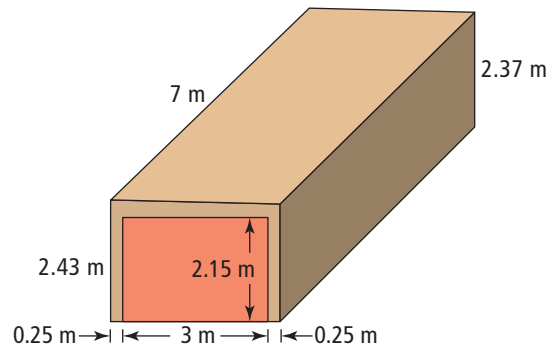
10. Use centimetre cubes to build the object shown.



- What is the object's surface area?
- Take the same ten cubes and build a rectangular prism. Estimate and then calculate whether the surface area remains the same. Explain with examples.

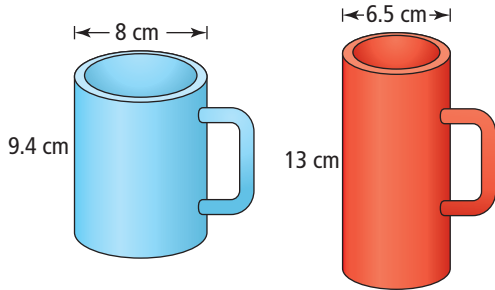
11. List places or situations in which surface area is important. Compare your list with those of your classmates.

12. Consider this drawing of a garage. The left side of the garage is attached to the house.



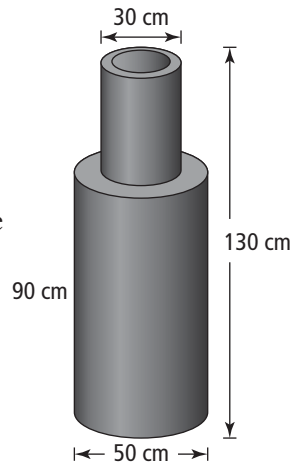
- What is the difference in height between the left-hand and right-hand sides of the garage? Explain why you would want a slight slant to a roof?
- Given that the house is attached to the left side of the garage, what is the surface area of the garage to the nearest hundredth of a square metre? What assumption(s) did you make in answering this question?

- 13.** A mug for hot beverages is to be designed to keep its contents warm as long as possible. The rate at which the beverage cools depends on the surface area of the container. The larger the surface area of the mug, the quicker the liquid inside it will cool.

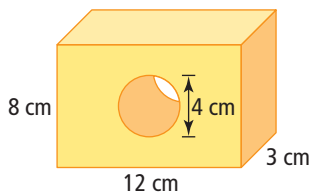


- a)** What is the surface area of each mug? Assume that neither has a lid.  
**b)** Which is the better mug for keeping drinks warm? Justify your answer.

- 14.** A chimney has the dimensions shown. What is the outside surface area of the chimney? Give your answer to the nearest hundredth of a square metre.

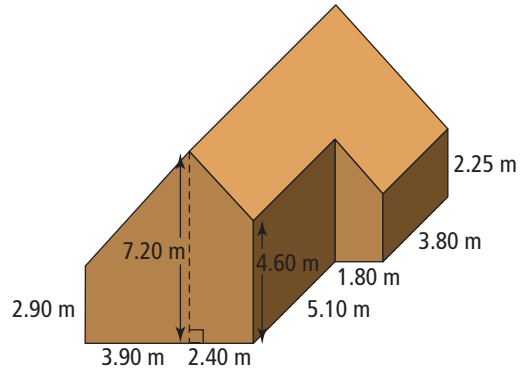


- 15.** Twila made the object shown.

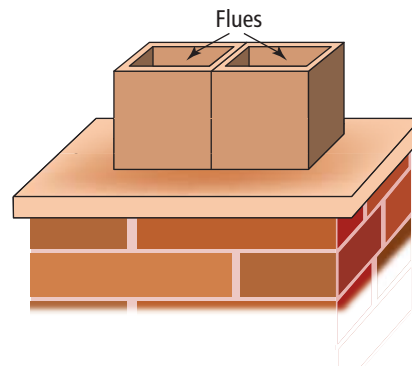


- a)** How can you use symmetry to help find the surface area of this object?  
**b)** What is the surface area?

- 16.** You are planning to put new shingles on the roof of the home shown.

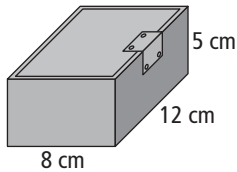


- a)** How many times would you need to use the Pythagorean relationship in order to find the area of the roof of the building shown in the diagram?  
**b)** What is the area of the roof that you cannot see in this figure, assuming that it is a rectangular roof?  
**c)** One bundle of shingles covers approximately  $2.88 \text{ m}^2$  and costs  $\$26.95$ . What does it cost for shingles to cover the roof?
- 17.** The hollow passages through which smoke and fumes escape in a chimney are called flues. Each flue shown is 2 cm thick, 20 cm high, and has a square opening that is 20 cm by 20 cm.



- a)** What are the outside dimensions of the two flues?  
**b)** If the height of each flue is 30 cm, what is the outside surface area of the two flues? Hint: Do not forget the flat edges on top.

18. A small metal box is shown. What is the inside surface area of the box? What assumptions did you make in finding your answer?

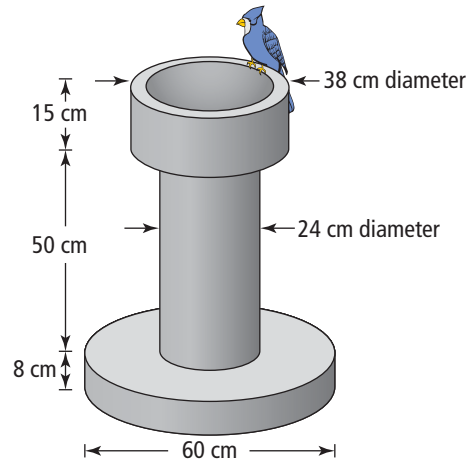


19. A party planner buys two plain cakes for a meal she is planning. One cake is square and the other is round. Both cakes are 6 cm thick. The square cake measures 25 cm along each edge. The round cake has a diameter of 25 cm.
- Sketch and label a diagram of each cake.
  - Show how to make four cuts to create eight equal pieces for each cake.
  - Estimate and then calculate how much the surface area increases after each cake is cut and the pieces are slightly separated.

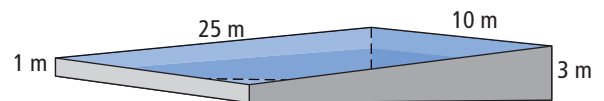
### Extend

20. Explain how surface area of individual grains of rice may affect the boiling of a cup of uncooked rice. Assume you have two kinds of rice. One has small grains and the other has larger ones. Consider each grain of rice to be cylindrical.
21. An elephant's ears are one of nature's best examples of the importance of surface area in heating and cooling. Research this phenomenon or another one that interests you. Write a brief report outlining the importance of surface area in heating and cooling. (Two other possible topics are why radiators have complex internal shapes and how a cactus minimizes surface area.)

22. The plan for a concrete birdbath is shown below. The bowl is a cylinder with a depth of 10 cm. If the bowl has a diameter of 30 cm, what is the exposed surface area of the birdbath, including the pillar and pedestal?



23. A swimming pool measures 25 m long and 10 m wide. It has a shallow end that is 1 m deep and gradually slopes down to a depth of 3 m at the deep end. The inside walls of the pool need repainting. Calculate the total area of the surfaces to be painted, to the nearest square metre.



### Math Link

Your design company wants to create a new product that will have a design printed on it. Your project team has suggested playing cards, business cards, memo pads, and sticky notes. Choose one of these items.

- What are the dimensions of your pack of cards or pad of paper?
- What is the surface area of your pack of cards or pad of paper?

# Chapter 1 Review

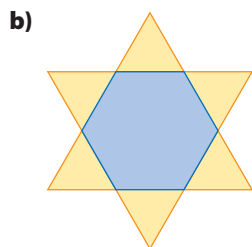
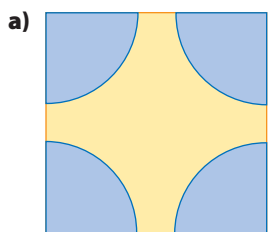
## Key Words

For #1 to #6, choose the letter that best matches the description.

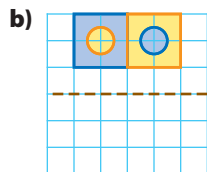
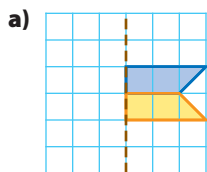
- |   |                            |
|---|----------------------------|
| 1. another name for a reflection line                                       | <b>A</b> line              |
| 2. type of symmetry in which the shape can be divided into reflected halves | <b>B</b> rotation          |
| 3. what you are measuring when you find the area of all faces of an object  | <b>C</b> angle of rotation |
| 4. type of symmetry in which a shape can be turned to fit onto itself       | <b>D</b> surface area      |
| 5. number of times a shape fits onto itself in one turn                     | <b>E</b> line of symmetry  |
| 6. amount of turn for a shape to rotate onto itself                         | <b>F</b> order of rotation |

### 1.1 Line Symmetry, pages 6–15

7. How many lines of symmetry does each design have? Describe each possible line of symmetry using the terms *vertical*, *horizontal*, and *oblique*.

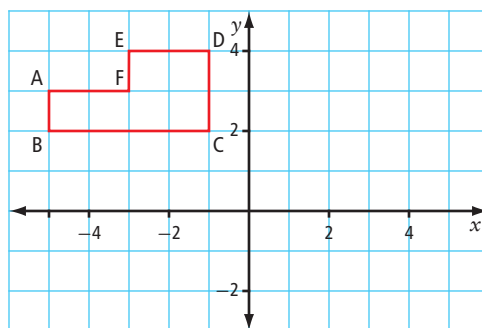


8. Half of a figure is drawn. The dashed line represents the line of symmetry. Copy and complete the figure on grid paper.



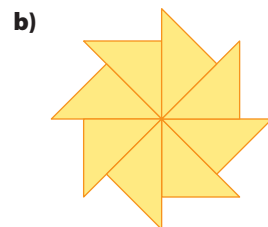
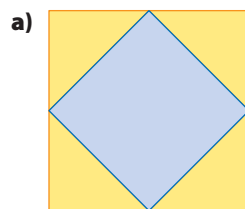
9. Determine the coordinates of the image of points A, B, C, D, E, and F after each transformation. Which of these transformations show symmetry? Describe the symmetry.

- a) a reflection in the  $y$ -axis  
b) a translation  $R6, D3$

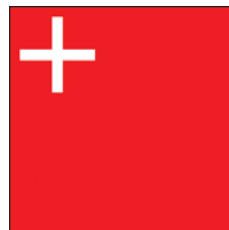


### 1.2 Rotation Symmetry and Transformations, pages 16–25

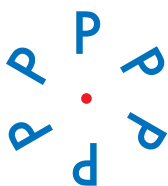
10. What is the order and angle of rotation symmetry for each shape? Express the angle in degrees and in fractions of a turn.



11. Write a brief description of any symmetry you can find in this square flag. Compare your ideas with those of a classmate.

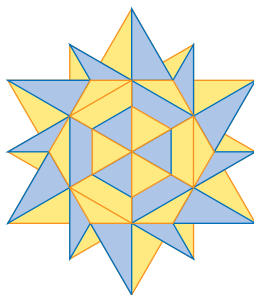


12. The arrangement of Ps has rotation symmetry, but no line symmetry.



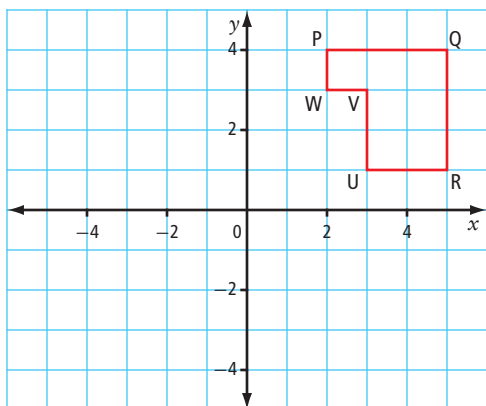
- a) Show a way that you can arrange six Ps to make a design that has both types of symmetry.
- b) What letter(s) could you place in the original arrangement that would have both line and rotation symmetry?

13. Examine the design carefully. Does it have rotation symmetry, line symmetry, or both? Explain.



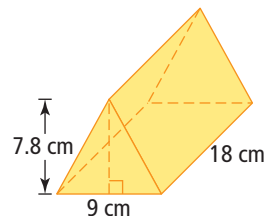
14. Create a coordinate grid that will allow you to do the transformations. Give the coordinates for the image of points P, Q, R, U, V, and W. Are the original and each image related by symmetry? If yes, which type(s) of symmetry?

- a) rotation counterclockwise  $180^\circ$  about the origin
- b) reflection in the  $x$ -axis
- c) translation 7 units left

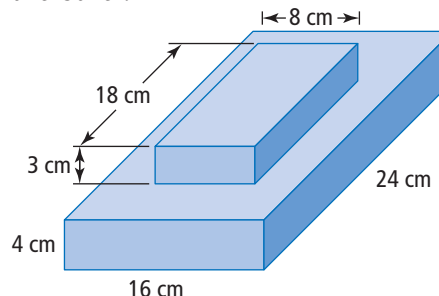


### 1.3 Surface Area, pages 26–35

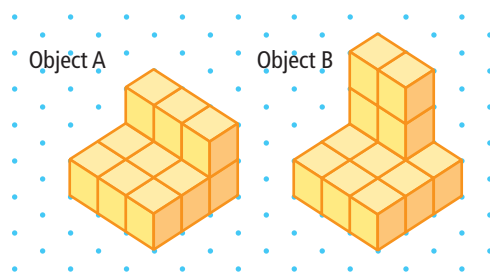
15. The triangular prism shown has one of its triangular ends placed against a wall. By what amount does this placement decrease the exposed surface area of the prism?



16. Two blocks are placed one on top of the other.



- a) What is the total surface area for each of the blocks when separated?
- b) What is the exposed surface area of the stacked blocks?
17. Use centimetre cubes or interlocking cubes to build the solids shown in the sketches.



- a) What is the exposed surface area of Object A?
- b) What is the exposed surface area of Object B?
- c) What is the minimum exposed surface area for a new object formed by sliding Object A against Object B? Do not lift them off the surface on which they are placed.

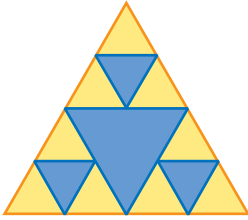


# Chapter 1 Practice Test

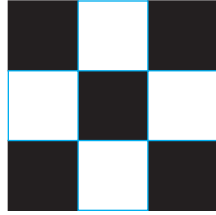
For #1 to #4, choose the best answer.

1. Which design has rotation symmetry of order 2?

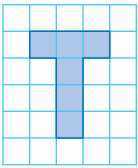
A



B



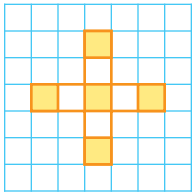
C



D



2. How many lines of symmetry are possible for the design?



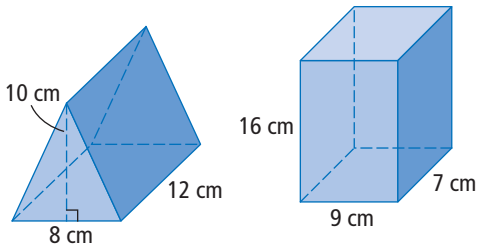
A 0

B 1

C 2

D 4

3. Two prisms are shown.



Imagine that the triangular prism is placed so that one triangular face is against the 9 cm by 16 cm face of the rectangular prism. How much less is the total surface area of this composite object than when the two objects are separated?

A  $40 \text{ cm}^2$

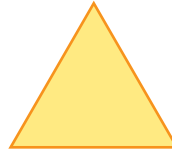
B  $80 \text{ cm}^2$

C  $144 \text{ cm}^2$

D  $160 \text{ cm}^2$

4. Which figure has only one type of symmetry?

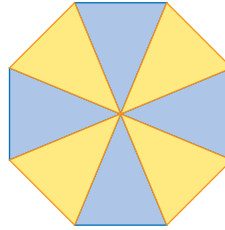
A



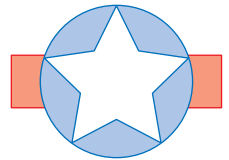
B



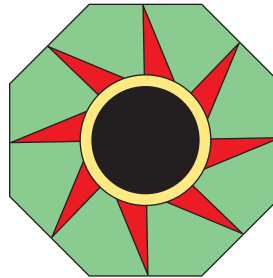
C



D



5. The design has rotation symmetry.



- a) Its order of rotation is ■.

- b) The angle of rotation is ■ degrees.

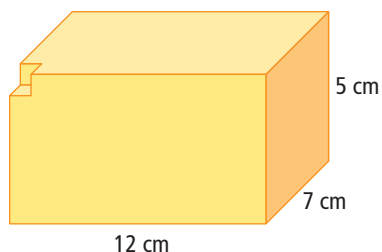
## Short Answer

6. Use the upper case letters shown.

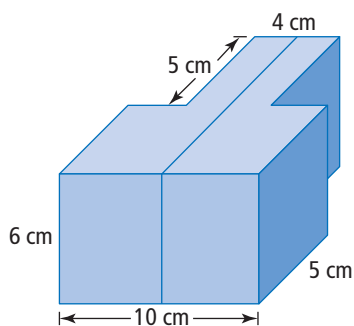
A B C D E F G H I J K L M N  
O P Q R S T U V W X Y Z

- a) Which letters have line symmetry?  
Indicate if each line of symmetry is horizontal, vertical, or oblique.
- b) Which letters have rotation symmetry where the angle of rotation is  $180^\circ$ ?

7. A rectangular prism has a 1 cm cube cut out of each of its eight corners. One of the cutouts is shown. What is the ratio of the original surface area to the new surface area? Explain.



8. Imagine that the object is cut in half at the blue line. If the two pieces are separated, by how much is the surface area of each half increased?



### Extended Response

9. Build rectangular prisms that each use 36 one-centimetre cubes.
- What are the dimensions of the rectangular prism that has the greatest surface area?
  - What are the dimensions of the rectangular prism with the least surface area?
  - What do you conclude from this?
10. Look at the stained glass window. Write two paragraphs describing the symmetry in the window. In the first paragraph, describe the line symmetry. In the second paragraph, describe the rotation symmetry.



### Math Link: Wrap It Up!

You have been asked to present the product idea you developed in the Math Link in section 1.3.

- Include the design for the individual cards or pieces of paper with at least one line of symmetry. Describe the type of symmetry your design exhibits.
- Create a design for the cover of a box that will hold your product. This design must exhibit rotational symmetry, and it may also exhibit line symmetry.
- Write a description of the dimensions of a box needed to hold the deck of cards or pad of paper. What are the dimensions and surface area of this box?
- Your company also wants to explore the possibility of distributing a package containing six boxes of your product, wrapped in plastic. What is the total surface area of six individual boxes of your product? What would be the surface area of six of these boxes wrapped together? Explain how you would package these so that they would have the smallest surface area.